

U.S. Solar Mounts

USSM-AGM4 Series Installation Manual

REV 6

Adjustable -Tilt, Multiple - Pole Racking Systems



Ultra-Rugged Solar Mounting Solutions

©2020 U.S. Solar Mounts Corp. All Rights Reserved

INTRODUCTION	3
AVAILABLE OPTIONS	3
CUSTOMER SUPPORT	3
1. INSTALLER RESPONSIBILITY	4
2. SAFETY NOTICES, WARNINGS & CAUTIONS	5
3. AGM SYSTEM OVERVIEW	7
4. AGM SYSTEM COMPONENTS	8
5. SITE ENGINEERING & PREP	9
5.1 SITE ENGINEERING & PLANNING	9
5.2 PLANNING FOR HEAVY EQUIPMENT NEEDS	9
6. INSTALLING PILINGS	10
7. RECEIVING SHIPMENT & SITE REQUIREMENTS	12
7.1 STAGING AREA	12
7.2 HEAVY EQUIPMENT	12
7.3 UNLOADING PROCEDURE	12
7.4 TOOLS NEEDED	12
7.5 MECHANICAL SYSTEM OVERVIEW	13
7.6 MECHANICAL SYSTEM ASSEMBLY	13
7.7 VERIFY POST ALIGNMENT AND HEIGHT	13
8. ABOUT SETTING THE ELEVATION ANGLE	14
9. PREPARE THE CRADLE ASSEMBLY	15
10. INSTALL THE CRADLE ASSEMBLY(S) ONTO THE POLES	16
11. CRADLE ALIGNMENT	17
12. INSTALL TORQUE TUBES AND CLAMPS	18
13. ATTACH MODULE RAILS TO THE TORQUE TUBES	20
14. MOUNTING THE MODULES	21
15. OPTIONAL EQUIPMENT – WIND BRACE INSTALLATION	24
16. ADJUST THE ARRAY ELEVATION	25
17. U.S. SOLAR MOUNTS LIMITED WARRANTY	26

INTRODUCTION

Included in this manual are instructions for prepping, assembling, and installing a single USSM-AGM4 manual-tilt photovoltaic racking system. These will include all processes from setting the foundation through mounting the photovoltaic modules to the racking system. Please read through the entire manual carefully before beginning any work related to the installation of the AGM4 racking. Also included with this manual will be separate provisional instructions for any/all optional items ordered with the corresponding rack. Be aware of when to install these optional items before beginning assembly.

AVAILABLE OPTIONS

The AGM4 Racking System has many available options:

- Cable Struts – Wire Management Channels
- Extrusion Slot Covers
- Extrusion End Caps
- High-Wind Brace Kits
- DC Actuator for Elevation Adjustment
- Optical Tracking Controls
- GPS/Algorithm-Based Tracking Controls
- Motion Damper Kits for Manual or Auto-Tracking Systems
- Aluminum Mounting Plate Kits for Inverters, Disconnects, Etc.
- Torque-Tube Clamping U-Bolts

The USSM-AGM4 Series racking mounts onto the following:

- 4" SCH40/SCH80 Structural Steel Pole (4 1/2" OD)

CUSTOMER SUPPORT

U.S. Solar Mounts makes every effort to ensure your racking system is easy to install. If you need assistance at any point with your installation or have suggestions on how we can improve your experience, call U.S. Solar Mounts' customer support. We do appreciate your feedback.

U.S. Solar Mounts

**3498 Acorn Ave.
Sparta, WI 54656**

(608)272-3999

info@ussolarmounts.us

1. INSTALLER RESPONSIBILITY

The installer is solely responsible for:

- Complying with all applicable local or national building codes, including any that may supersede this manual.
- Ensure that U.S. Solar Mounts and other products are appropriate for the particular installation and the installation environment.
- Ensure that the selected mount can support the array under live load conditions.
- Use only U.S. Solar Mounts parts and installer-supplied parts as specified by U.S. Solar Mounts. Substitution parts may void the warranty.
- **Ensure proper array/structure grounding**, including each module frame, the mounting pole, torque tubes and each rail. Failure to provide proper grounding may result in damage to your equipment or injury to personnel.
- **Do not rely on the mounting pipe to act as a ground rod!** It is not a reliable substitute for a properly installed grounding electrode system.
- **If you are unfamiliar** with NEC **compliant** solar electric installations, consult **with the dealer** that supplied your mount. They should have the skill and expertise to supply you with the necessary wiring diagrams and the appropriate connection wire, grounding equipment, junction boxes and fusing.



Installation or service performed by unqualified and/or untrained personnel increases the risk of bodily injury and/or property damage.

2. SAFETY NOTICES, WARNINGS & CAUTIONS

This chapter contains important safety instructions. You must read, understand, and comply with all of these safety instructions in order to protect your life and safety, and to prevent equipment problems or damage. Failure to follow the instructions in this chapter may void equipment warranties.

Types of Safety Notices

Safety warnings are not in this manual for our benefit; **they are for you**. Please follow them carefully. We do not want you to become a statistic.

The following notices appear throughout this manual:



WARNING!

Warnings alert you to the possibility of death or personal injury if these instructions are not followed.



CAUTION!

Cautions alert you to the possibility of equipment damage if these instructions are not followed.



Electrical Safety

- USSM AGM installations may require working near high voltage electrical equipment. Shocks caused by electricity can be fatal. Use extreme caution at all times to avoid creating an electrocution hazard.
- There is an increased risk of electric shock if your body is grounded.
- **Never work on energized components.** Shut off all sources of electric power and follow up with the proper use of lock-out / tag-out equipment.

DON'T TRUST ANYONE ELSE! Verify for yourself that the equipment is de-energized!!

Electrocution Hazard!

Every piece of the structure is electrically conductive.
Check for clearance to overhead power lines before beginning any install.



WARNING!



We make every effort to remove sharp edges from our galvanized products. However, we highly recommend wearing gloves when handling metal parts in order to avoid sharp edges.

3. AGM SYSTEM OVERVIEW

DESCRIPTION

The U.S. Solar Mounts AGM is a low-profile, ground-mounted racking system for commercially available photovoltaic modules. The AGM System is ruggedly constructed and very robust. Its design allows for simple and easy seasonal adjustment to optimize performance at various locations.

The AGM System can be fitted with electric actuators that will allow it to be used as an E-W single-axis tracker. On sites that do not allow for E-W tracking, an actuator can instead be used to automatically adjust elevation throughout the day.

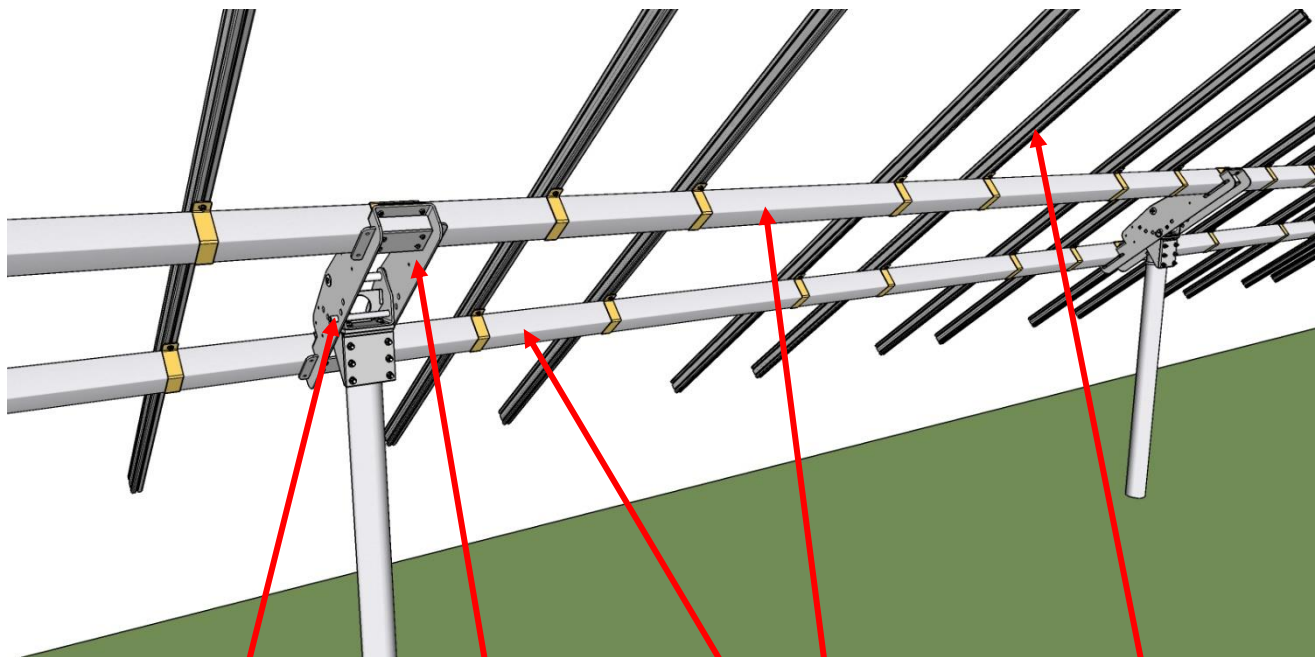

Angle Locking Pin

Cradle Assembly

Torque Tubes

Module Rails

Basic System Components

4. AGM SYSTEM COMPONENTS

<p>Cradle Assembly</p> <p>Fully assembled. Includes angle locking pin.</p>	<p>One (1) assembly per pole.</p> <p>Quantity varies with system size/design.</p>
<p>Torque Tube Clamps</p> <p>Includes: 8, 1/2"-13 HDG Bolts 8, 1/2" HDG Flat Washers 8, 1/2"-13 HDG Hex Nuts 12, 1" #12 Tek Screws</p>	<p>One (1) pair per Cradle.</p> <p>Quantity varies with system size/design.</p>
<p>Torque Tube Straps</p> <p>Includes 5/16" Stainless Hardware.</p>	<p>Two (2) pair per module column.</p> <p>Strap design may vary if optional equipment selected. Total quantity is system-dependent.</p>
<p>Set Screws</p> <p>3/8"-16 x 3/4"</p>	<p>Three (3) per Cradle.</p> <p>Usually come installed in Cradle</p>
<p>Angle Locking Pin</p> <p>3/4" x 8" Pin Ships installed in the Cradle assembly.</p>	<p>One (1) per Cradle.</p> <p>Finishes: Standard: Zinc Plated Optional: Stainless Steel</p>
<p>Module Rails, 120"</p> <p>Extruded Aluminum Satin Anodized</p>	<p>Two (2) rails per module column.</p> <p>Quantity varies with system size/design. Length may vary slightly based on module brand.</p>
<p>Torque Tubes</p> <p>4" Steel Structural Tube HDG</p>	<p>Two (2) per section</p> <p>Length varies with system size and design.</p>

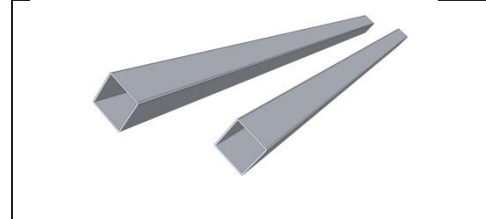
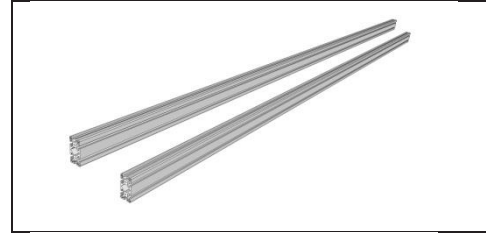
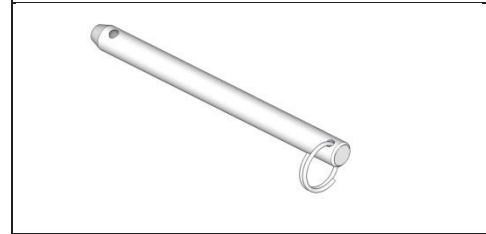
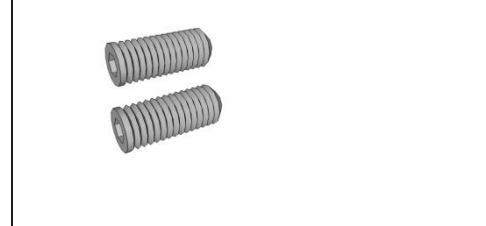
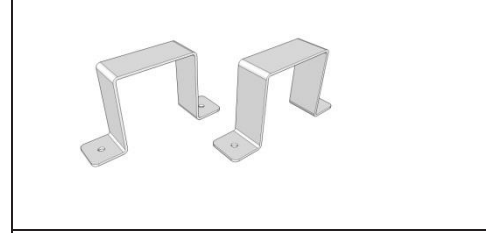
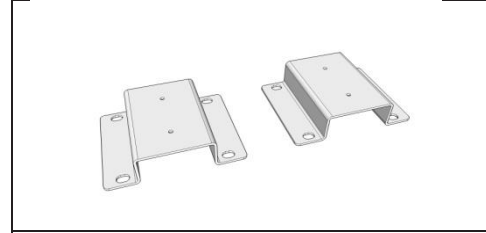
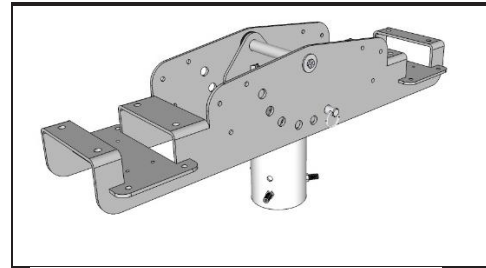

5. SITE ENGINEERING & PREP

ABOUT THIS CHAPTER

This chapter covers the tasks that must be performed before the AGM4 System arrives.

These tasks include:

- Site Engineering
- Site Planning
- Site Preparation

Once these tasks have been completed, the AGM4 System may be unloaded and installed.

5.1 SITE ENGINEERING & PLANNING

- Anchor posts must withstand a wind load of 3400 lb. in the horizontal direction at the finish height of the posts.
- Specify the wind rating for the site where the AGM4 will be installed. This will be used for the engineering of concrete pilings used to anchor the steel posts.
- Piling layout is determined by PV module size, and is site-specific.

The site chosen for the installation of the AGM4 System must have adequate access for delivery trucks, semi-tractors and other various types of heavy equipment.

Please Note: Assistance with shipping and logistics may be requested by USSM.

Engineering & Site Preparation

5.2 PLANNING FOR HEAVY EQUIPMENT NEEDS

Heavy equipment may be needed for preparing the ground surface, drilling/driving pilings and trenching operations

An all-terrain forklift or loader may be desired for unloading and moving the AGM4 equipment.

6. INSTALLING PILINGS



CAUTION! The proper functioning of the AGM4 System depends on all posts being correctly installed and aligned within the specifications described here. Failure to properly install and align posts can result in binding, excess wear, shortened system life, and parts failure. Equipment failure due to improper piling installation/alignment is not covered under warranty.

- 6.1 The post spacing/layout is site-specific and is determined by the module size. Standard 4" SCH40 pilings must have a height of no more than 66" and be capable of withstanding 3200 lb. wind load at grade. Posts must be 4" inside diameter (4 1/2" OD), rated SCH40 MINIMUM. Schedule 80 tubing may be used in place of Schedule 40. Verify that the OD is no greater than 4 1/2".
- 6.2 Install all posts according to your site layout plan. As shown below, posts can be a maximum of 16' apart for center posts and 15' apart on each end, and can be a maximum of 66" tall when finish cut.
- 6.3 Ensure that the post tops are level over the entire length of the row. Cut as needed, but double-check that the lowest edge of the array will clear the ground when tilted.

Alignment of the posts in a row is critical.
Ensure that all posts are +/- 1/2" of the centerline of the row.

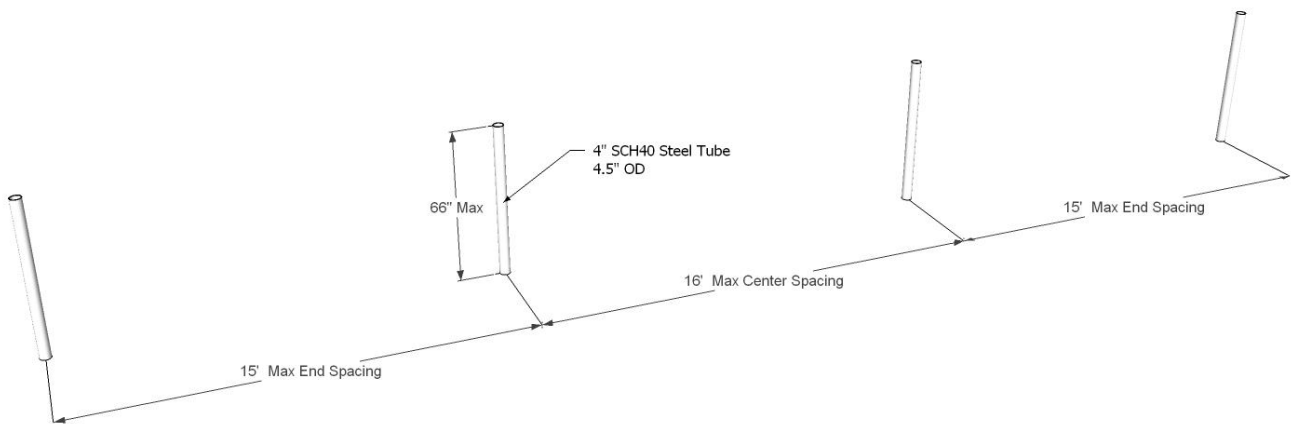

INSTALLING PILING AND POSTS, CONTINUED



CAUTION! When installing the mounting posts, ensure that there is no more than $\frac{1}{2}$ " deviation from the center-line of a row.

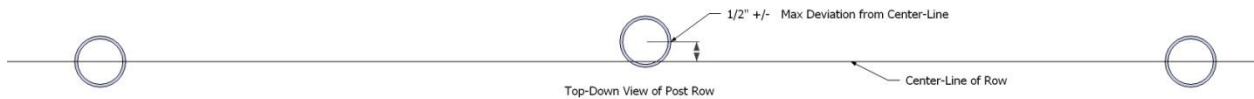

CAUTION! Before cutting posts to height, verify that the ground will not interfere with the bottom edge of the elevated array. Refer to your Array Layout Drawings.

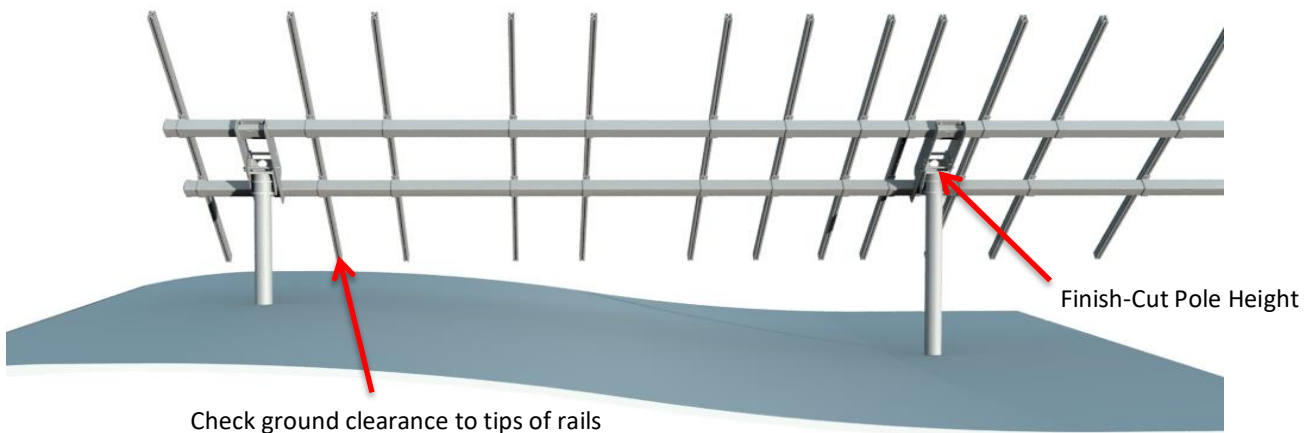

7 RECEIVING SHIPMENT & SITE REQUIREMENTS

7.1 STAGING AREA

In order to arrange the parts for easy installation, an adequately-sized staging area is needed for the AGM4 System once it is unloaded.

7.2 HEAVY EQUIPMENT

You may wish to use heavy equipment such as an all-terrain forklift or track loader for unloading your shipment and to relocate materials on the jobsite. It is worth noting that any individual piece of any AGM4 Racking System can be handled by no more than 2 men, making it ideal for remote site installations where the use of heavy equipment is either not possible or not desired.

7.3 UNLOADING PROCEDURE

1. Download all boxes, skids/pallets.
2. Examine Bill of Materials and items received. Check for accuracy and completion.
3. Move materials & parts to the staging area and arrange so as to facilitate easy assembly of the array(s).

7.4 TOOLS NEEDED

The following chart lists the basic tools required to assemble the AGM4 Racking System.

Wrenches		Sockets		Other	
	7/16" Combination Wrench		7/16" Socket		Ratchet Wrench
	1/2" Combination Wrench		1/2" Socket		Impact Driver
	7/8" Combination Wrench		3/4" Socket, Deep		Transit
	3/4" Combination Wrench		7/8" Socket		Gloves
	Adjustable Wrenches				Laser Level
					Portable Band Saw
					Eye Protection
					Hearing Protection

RECEIVING SHIPMENT & SITE REQUIREMENTS - CONTINUED

7.5 Mechanical System Overview



WARNING! The AGM4 System is constructed of parts that are very heavy. Use proper lifting equipment and techniques while moving parts and assembling the AGM4 Rack. Failure to observe this warning could result in serious personal injury or death.

7.6 Mechanical System Assembly

As you assemble the AGM4 System, refer to the following illustrations of completed mechanical assemblies. The procedures will guide you step-by-step through the assembly process.



CAUTION! The proper functioning of the AGM4 System depends on all posts being correctly installed and aligned within the specifications described here. Failure to properly install and align posts can result in binding, excess wear, shortened system life, and parts failure. Equipment failure due to improper piling installation/alignment is not covered under warranty.

7.7 Verify Post Alignment and Height

Before beginning installation:

1. Check, and double-check, that all posts are placed exactly according to your site layout plan.
2. Verify that all posts have been cut level for each row.



CAUTION! The Main Cradle assembly is, by design, a rotating assembly. Use care while preparing, installing and rotating the Cradle. Avoid getting your hands or fingers between any of the movable parts. Injury will likely occur if you do not follow this warning!

8. ABOUT SETTING THE ELEVATION ANGLE

The Main Cradle has a series of 6 positioning holes that provide a secure angle setting for various array elevations. The Main Pivot has 2 through sets of locking holes; 1 North, 1 South.

The Angle Locking Pin will be installed through the desired angle selection hole in the Cradle, and through either the North or South hole in the Pivot, as shown in the figure below.

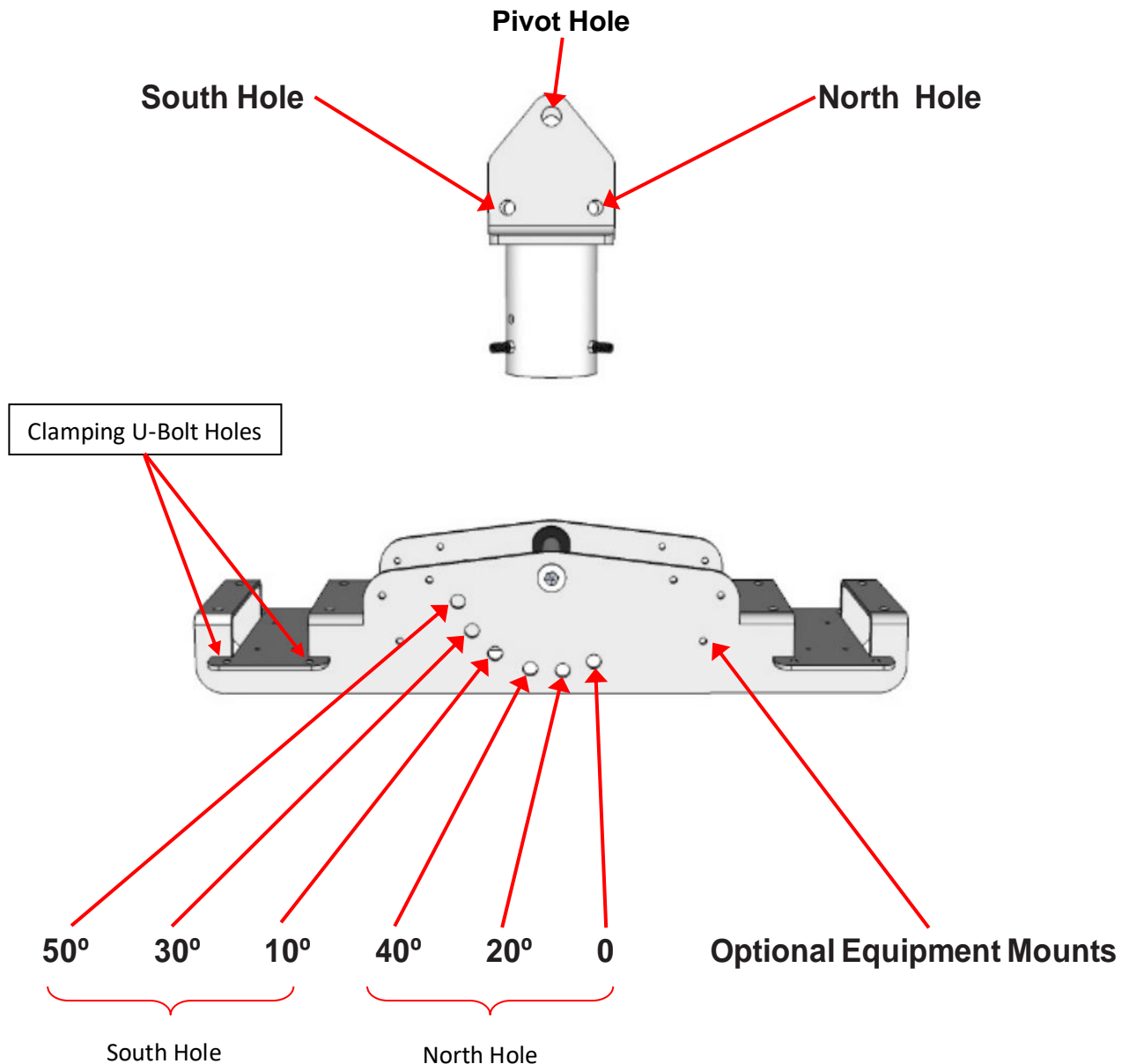

Important Note

Make sure to look through any/all supplemental manuals included for the installation of optional equipment selected before proceeding to ensure the proper steps are taken when needed to allow their successful install.

9. PREPARE THE CRADLE ASSEMBLY

Each individual Cradle Assembly may be shipped with the Main Pivot rotated fully within the main Cradle and the Angle Lock Pin installed to capture it. See Fig. 1

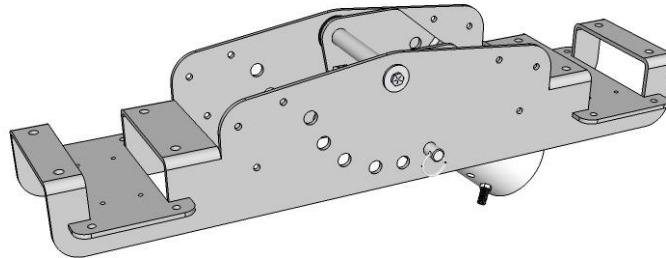

Fig. 1

- 9.1 With the Cradle Assembly resting on the ground or on a suitable work surface, remove the Angle Locking Pin from the Cradle. Rotate the Main Pivot downward so that it is arranged as shown in Fig. 2 below. Reinstall the Angle Locking Pin through the 0° hole.

It is easiest to perform this task with the Cradle on its side with the ring end of the pin UP.

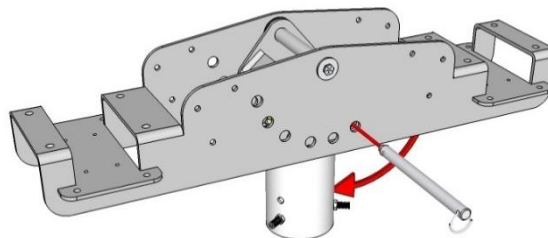

Fig. 2

- 9.2 Locate three (3) galvanized U-bolts and their nuts & flat washers. Install the U-bolts, nuts and washers as shown in Fig. 3 below. Install the washers and nuts just far enough to give a full nut. Leave the U-bolts loose.

Fig. 3

10. INSTALL THE CRADLE ASSEMBLY(S) ONTO THE POLES

Each Cradle Assembly can now be placed onto the top of the poles. Ensure that the Cradle is installed with the angle positioning holes facing the proper direction as shown below.

NOTE: TIGHTEN SET BOLTS FINGER-TIGHT ONLY.

They need to stay loose until after all Cradles are properly aligned AND the Torque Tubes are installed.

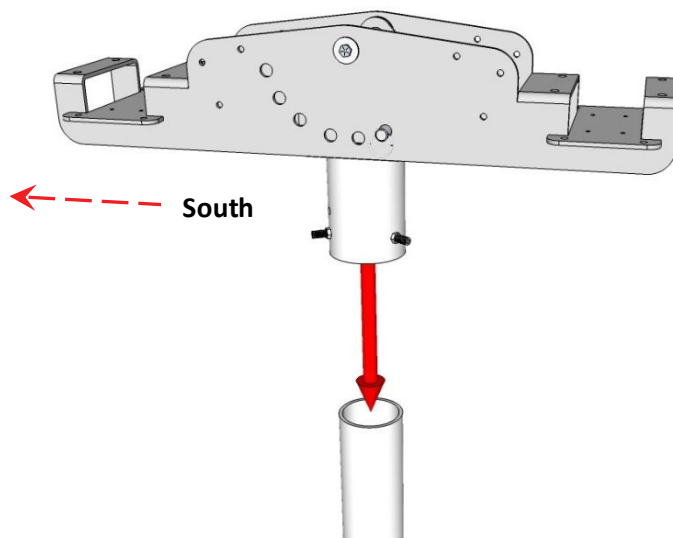

Fig. 4

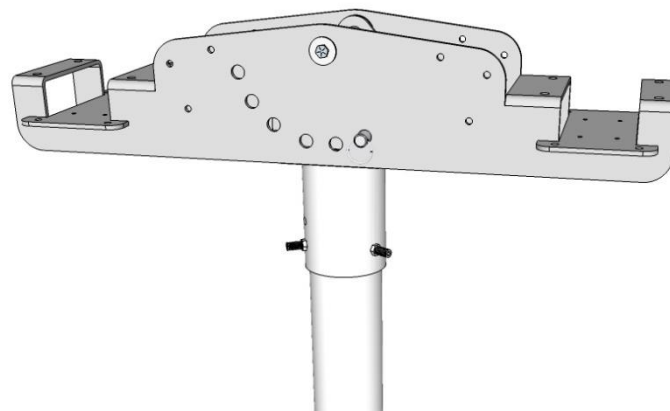

Fig. 5

11. CRADLE ALIGNMENT

- 11.1** The Main Pivot has been designed to allow for N-S adjustment should there be a misalignment on the poles. The Main Pivot will adjust $\pm \frac{1}{2}$ " from the centerline of the row. If adjustment is needed, loosen the 4 Top Plate bolts, slide the assembly North or South and re-tighten securely. A string, laser or transit may be used for this purpose, depending on row length.

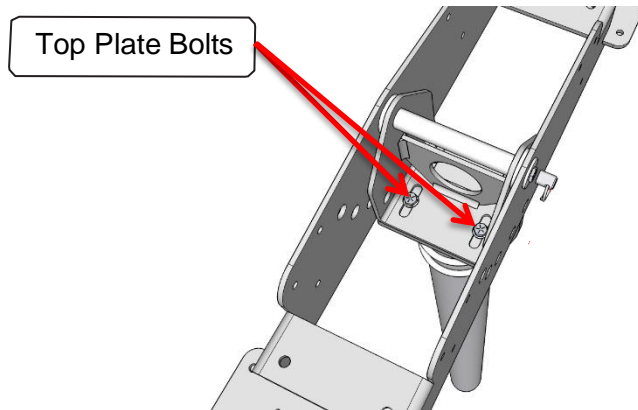

Fig. 6

- 11.2** The drawing below shows a top-down view of 3 Cradles mounted on their poles. Ensure that the pivot bolts are aligned with each other on the centerline of the row. The Cradles should rotate about a common centerline as if there were one long axle running through all of them.

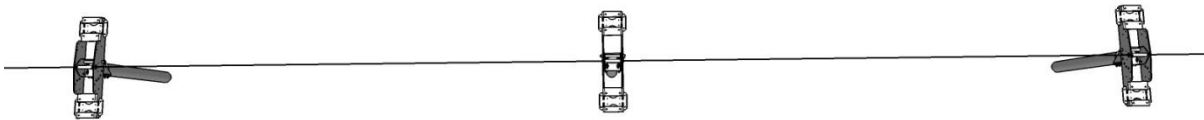

Fig. 7
Top-Down View of a Row

12. INSTALL TORQUE TUBES AND CLAMPS

- 12.1 Once all Cradles have been installed onto their poles, aligned, and the Set Bolts are finger-tight, the Torque Tubes can be installed into the Cradles. Torque Tube length will vary, depending on system design.

Refer to your layout drawing for the cantilever (overhang) length of the Torque Tubes.

Maximum cantilever for any installation is 24”

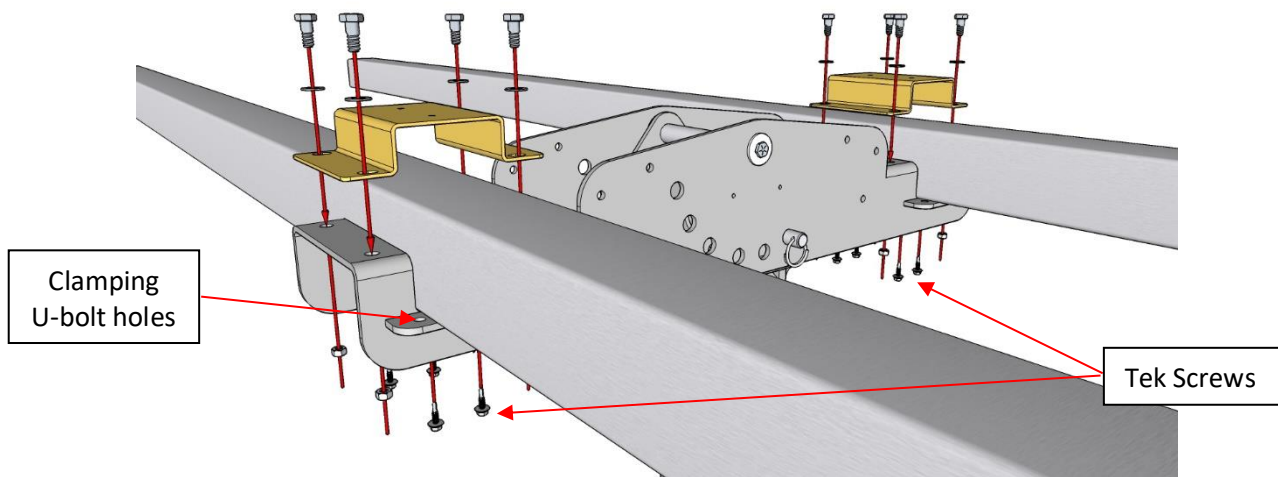

Fig. 8

Note: The drawing above depicts an outer-most pole assembly. Center pole assemblies may also serve as a connection point for multiple, end-to-end Torque Tubes. If a Cradle is serving as a connection point, ensure that each Torque Tube end is roughly centered in the Cradle. Also, refer to the Square U-Bolt Manual for any systems including the High-Wind Kits, as the Clamping U-Bolts can be installed at this time.

- 12.2 Install the Torque Tube Clamps over the Torque Tubes and onto the Cradles as shown above. Using four (4), 1/2"-13 bolts, nuts and flat washers, securely fasten the Clamps onto the Cradles. There should be a slight gap between the bottom of the Clamp and the top of the Cradle. Double-check to ensure the Torque Tubes are correctly spaced over the cradle before installing the 4 Tek Screws on each side (4 on bottom; 2 holes on the Clamps are optional) through the holes located in the Cradle.

Note: The 4 Tek Screws and the optional Clamping U-bolts (indicated above in Fig. 8) are used at Torque Tube splice points only. Installation for the U-bolts is covered in the separately included Square U-bolt Manual. If there are no splice points, no hardware will be included. Extra mounting hardware can be ordered for all Cradles as optional equipment if desired.

INSTALL TORQUE TUBES AND CLAMPS - CONTINUED

The final step of Torque Tube installation is to check for smooth, free rotation of the Cradles.

Refer to Figure 9.

- 12.3 Temporarily remove the Angle Locking Pins from all Cradles in the row.
- 12.4 By hand, move the mount through its full range of motion, **50° S** to **50° N**.
- 12.5 Return the rack to the 0° position
- 12.6 Reinstall all Angle Locking Pins.

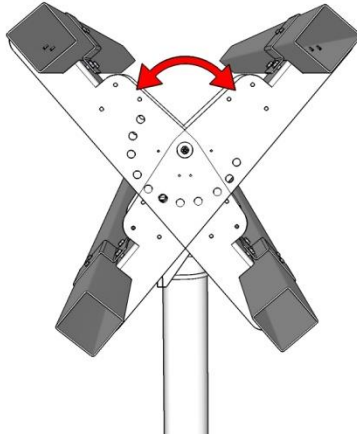

Fig. 9

What you are checking for:

- a. Does the rack move freely and smoothly, with slight resistance?
- b. Is there any sign of binding or friction?
- c. If excess friction / binding are evident, isolate the cause and adjust as necessary to give free movement.

NOTE:

At this point of the assembly process, the racking assembly will want to “hang” in the level position. You will have to exert some force to cause it to rotate.

13. ATTACH MODULE RAILS TO THE TORQUE TUBES

- 13.1 The Module Rails can be installed at this time. When placing the rails onto the Torque Tubes, ensure each rail is centered on the Torque Tubes in the N-S direction.

Improper centering of the rails will make tilting the rack much more difficult.

NOTE: East-West rail spacing is module and system-specific. Refer to your layout drawing for the 1st rail starter distance and rail spacing. The hole-to-hole distance on your module of choice is what determines the rail spacing distance.

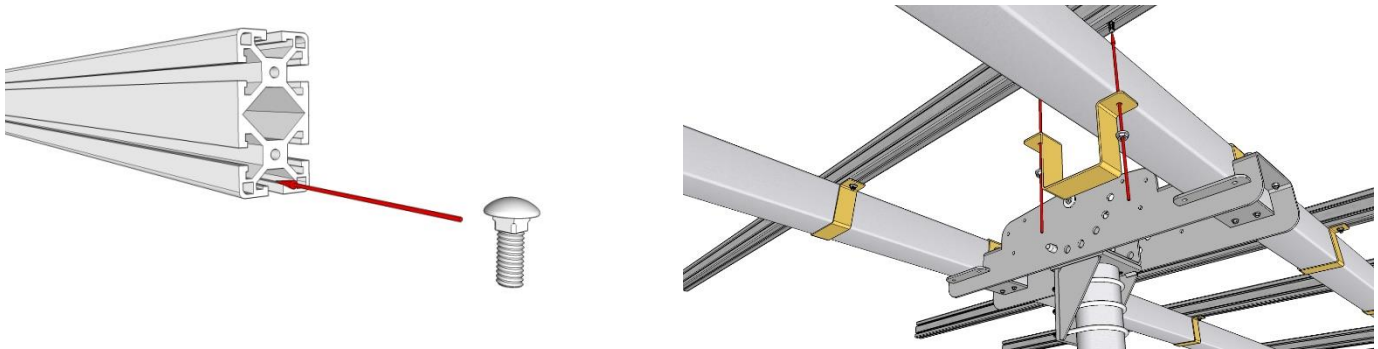

Fig. 10

- 13.2 **Rail #1:** Insert four (4) 5/16"-18 bolts into the end of the extruded rail. Slide them inward so that they will align with the holes in the Torque Tube Straps. Place the rail on top of the Torque Tubes at the appropriate location. Attach the Torque Tube Straps to the rails with the supplied bolts as shown above.

TIGHTEN THE STRAPS FINGER-TIGHT ONLY AT THIS TIME!!

IMPORTANT NOTE:

If WEEB Grounding Lugs are to be used, a 5th bolt will need to be slid into the rail slot. The location of this bolt depends on where you would like the ground lug to be located. In most cases, it is located on the South side of the North Torque tube. See the Optional Items section for further details.

- 13.3 **Rail #2:** Place the second rail onto the Torque Tubes at the proper distance from rail #1. Use the same procedure as in Step 2 to fasten the rail onto the rack.
- 13.4 Repeat for all remaining rails. Observe proper spacing throughout and remember to leave the rails loose for adjustment & square-up.

14. MOUNTING THE MODULES

- 14.1 With all rails in place, the modules must now be installed. Locate four (4) stainless steel carriage head bolts and serrated-flange nuts for each module.
- 14.2 Insert bolt through the WEEB Washer (if used), then through the module frame and loosely install a serrated-flange nut onto each bolt.
- 14.3 After all 4 bolts are in place, set the first (center) module onto the rail.

Module bolt location example:

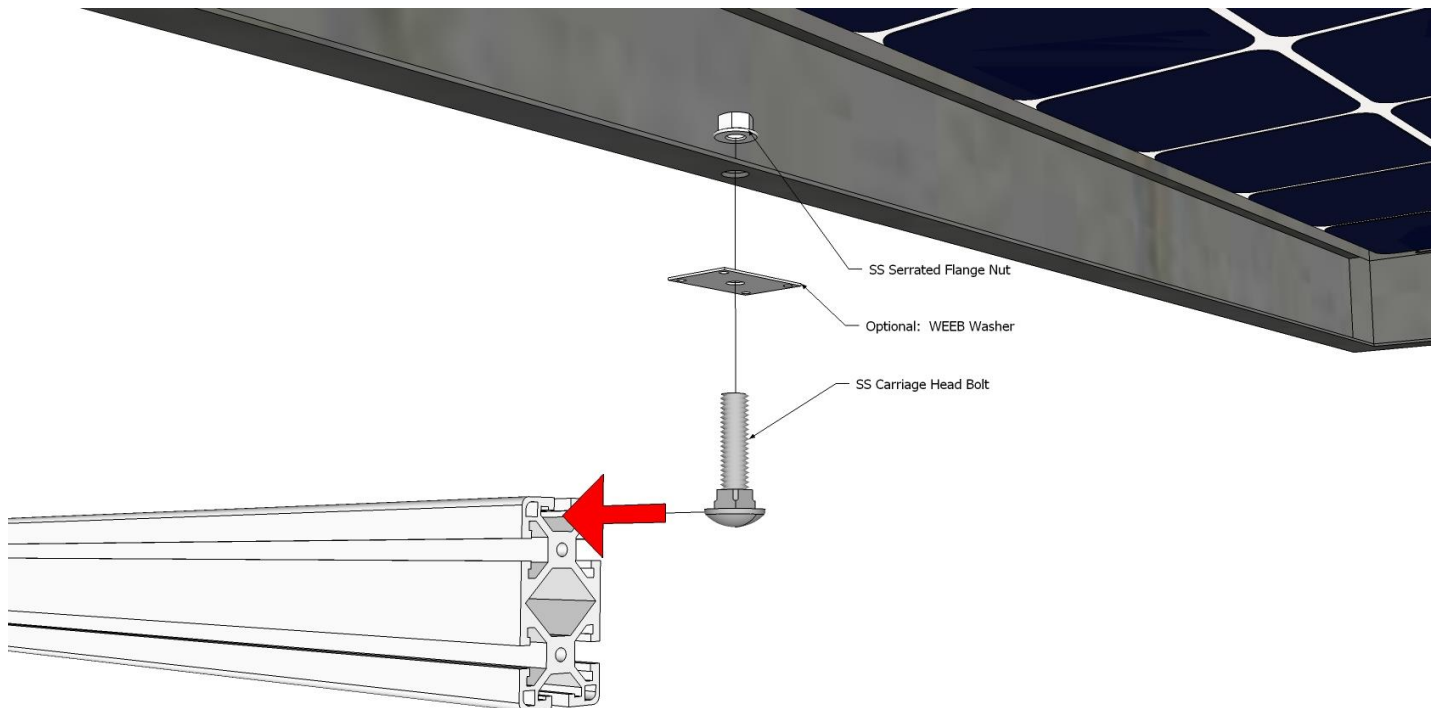
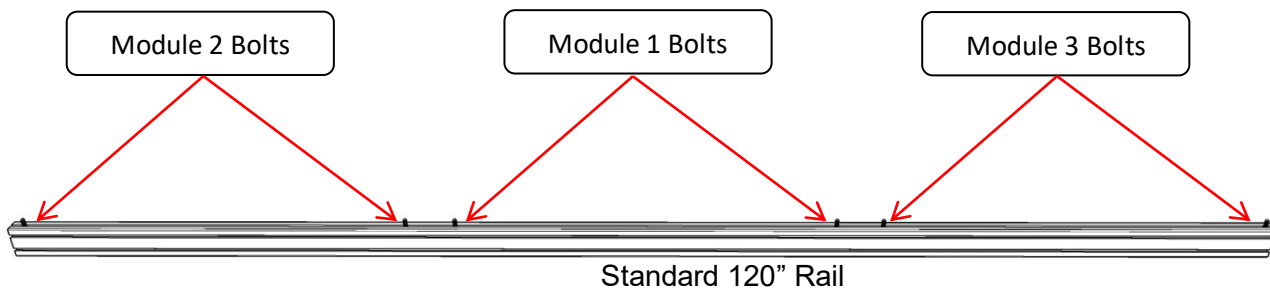

Fig. 11

- 14.4 Repeat the same process for the other 2 modules in the current column.

Mounting the Modules Continued

Once all 3 modules are in place:

- 14.5 Make sure that the rails are properly located on the Torque Tubes.
- 14.6 Ensure that the spacing between modules is equal.
- 14.7 Check that modules/rails are square on the Torque Tubes.

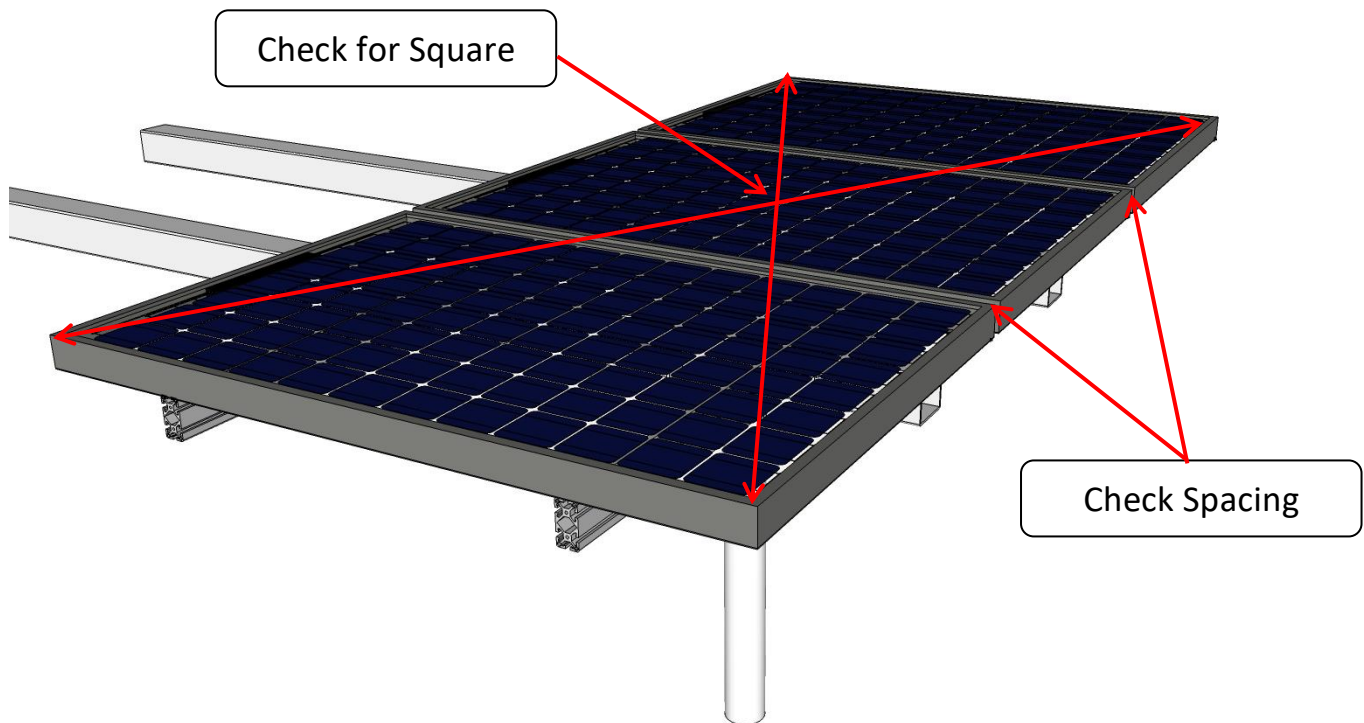

Fig. 12

Mounting the Modules Continued

- 14.8 After Column #1 is squared-up and properly positioned, tighten the 4 Torque Tube Straps' bolts securely.
- 14.9 Tighten the module bolts for this column at this time.
- 14.10 Repeat steps 14.1 through 14.9 for the remaining module columns, checking module and column spacing every 2-3 columns to ensure accurate alignment of the entire array.

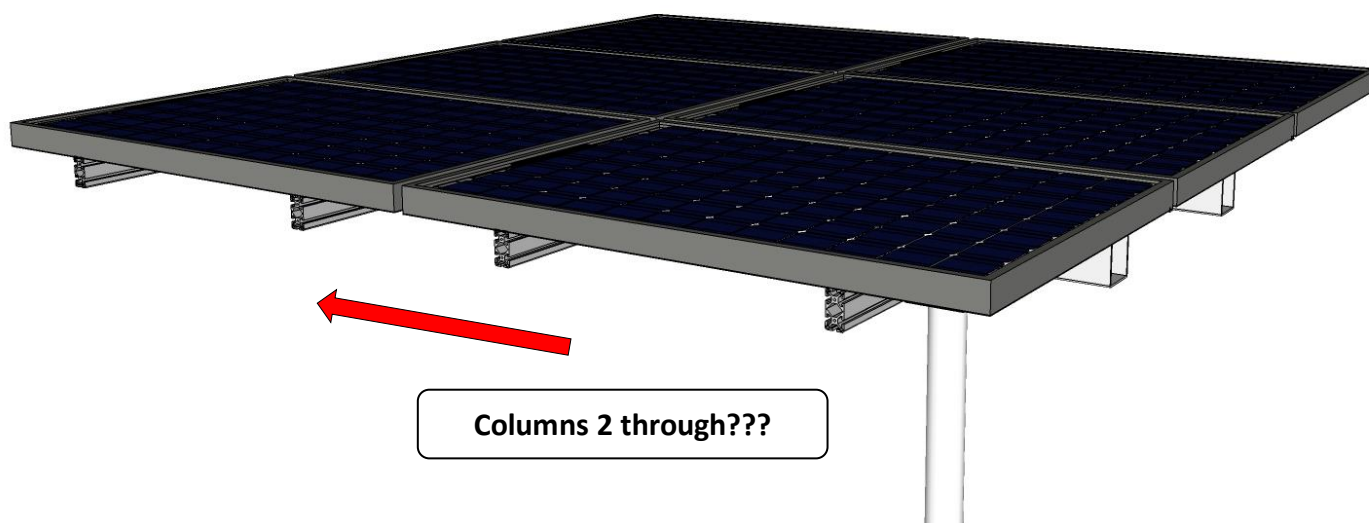

Fig. 13

15. OPTIONAL EQUIPMENT – WIND BRACE INSTALLATION

NOTE: If you ordered the optional Wind Braces, with the modules all in place and the Straps and rails secured, these can now be installed. The Wind Braces should be installed before the Wire Management Kit, if both items were added.

- 15.1 The Wind Brace Kit comes with gold “L” brackets that tek screw through the Rail Straps into the torque tubes, as shown in Fig. 14. You may want to pre-drill a pilot hole for the tek screws to help get them started into the torque tubes. The tall leg of the L should be facing towards the center of each individual panel column (each rail should alternate which direction the legs are facing)
- 15.2 With the brackets installed, slide a carriage bolt into the bottom slot of the Rail as shown in Fig. 15. Install the upper end of the Wind Brace so it hangs against the bottom of the Rail but leave the carriage bolt loose so the Brace can slide.
- 15.3 Use a 5/16 hex head bolt and another serrated-flange nut to attach the lower end of the Brace to the L bracket, then tighten both nuts.
- 15.4 Repeat steps 15.1 through 15.3 for each Brace (2 per rail).

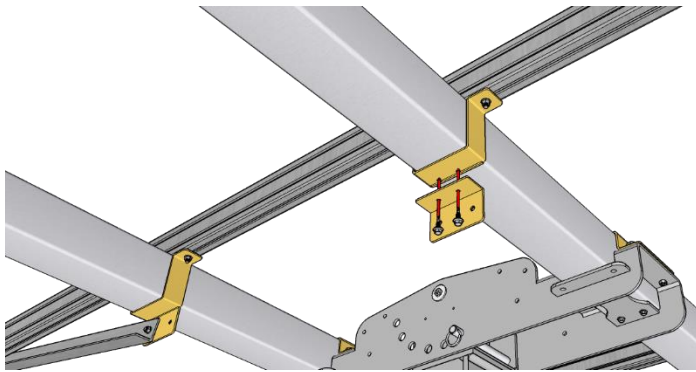

Fig. 14

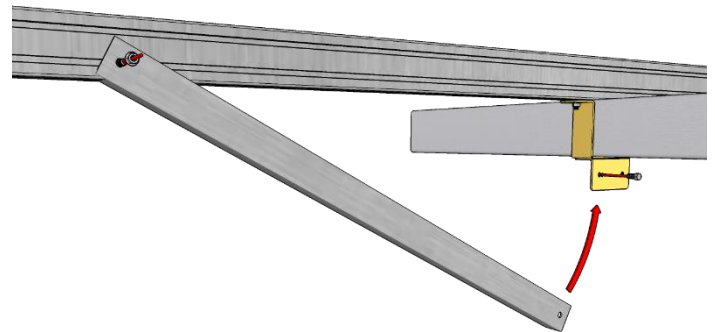

Fig. 15

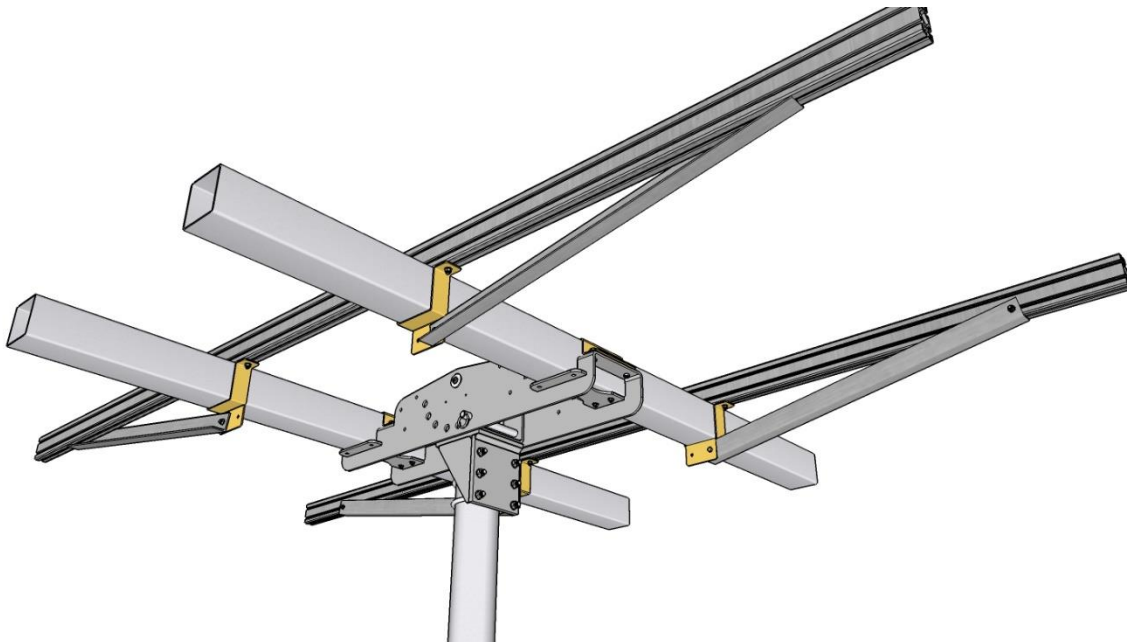

Fig. 16

16. ADJUST THE ARRAY ELEVATION

The array must now be rotated to the optimum elevation for your location.



CAUTION! Protective Headgear Required! The AGM4 is now a very large and very heavy structure. You must wear protective headgear during the Angle Adjustment process.



WARNING! In order to safely adjust AGM4 elevation, a minimum of three people should be used: One person in the center pulling and replacing pins and at least 2 people along the outer Southern edge of the array.



WARNING! Do not attempt to adjust elevation during windy conditions! The AGM4 System is designed to move freely. A strong gust of wind could cause you or your crew to lose control of the array. This condition could cause damage to the array and possibly result in very serious injury.

Failure to follow these WARNINGS can result in serious personal injury.

NOTE: Elevation adjustment must be completed one row at a time.

1. You must first determine what elevation is required for your location.
2. Remove all of the locking pins from the Cradle Assemblies in the row.
3. With the assistance of **at least 2 other people**, rotate the array until the desired elevation is achieved.
4. When the proper elevation hole has lined up with the locking hole, reinsert the pins.

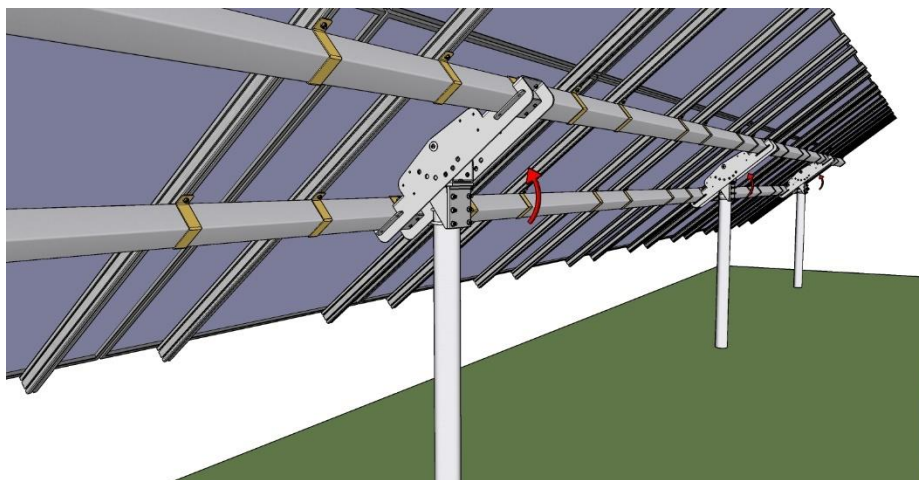

17. LIMITED WARRANTY

U.S. Solar Mounts Corp Racking Systems Limited Warranty

U.S. Solar Mounts Corp ("USSM") warrants the Solar Module Racking Systems that it manufactures to be free from defects in the materials and workmanship under normal application, use, and service conditions for a period of fifteen (15) years from the date of the original purchase. If a racking product fails or becomes inoperable due to manufacturing defects during the fifteen-year period of this warranty, USSM will, at its sole discretion, repair or replace the defective component(s), as, and to the extent, covered under this warranty. Equipment, components or materials supplied by third parties, sub-contractors, owners or any person, group, entity or organization other than USSM are not covered under this warranty. This limited warranty, shall transfer from the original buyer/end user to subsequent buyers/end users for the remainder of the warranty term provided the renewable system is not moved or relocated from its originally installed location or altered in any way.

Warranty Exclusions

If, in USSM's sole judgment, a racking system has been subject to misuse, neglect, accident or has been damaged through abuse, alteration, failure to follow USSM's or the manufacturers' operation & maintenance instructions or repaired by anyone other than USSM and its authorized dealers/installers, this warranty will not be applicable. This warranty does not cover finishes applied by third-party vendors such as galvanizing, anodizing, liquid or powdered paint. Should a failure occur, USSM reserves the right to examine the racking system in its entirety prior to any repairs, removal or modification of the system. Should USSM be denied the opportunity to examine the racking as-is and in-place, for any reason whatsoever, this warranty shall become null & void. This warranty will not cover damage due to acts of God, power failures, lightning, fire, flood, severe weather or conditions that exceed the racking system's design limitations, hailstorms, insect and pest infestation, and other events reasonably beyond USSM's control. USSM reserves the right to use refurbished or repaired products or components as repair or replacement parts for any warranty claim. Warranty coverage does not include costs associated with de-installation or re-installation of any product being replaced or repaired under this Limited Warranty or any transportation costs for return of components or for reshipment of any repaired or replaced products, parts or components.

Limitations of Warranty and Liability

USSM makes no warranties whatsoever regarding materials or components not manufactured by USSM. However, USSM does, for materials and/or components purchased through USSM, hereby assign and pass through to the system owner all manufacturers' warranties for the materials and/or components, to the greatest extent such warranties are assignable. If, during the USSM warranty period, a component fails, USSM will work with the manufacturer to obtain a replacement part(s). USSM will charge for labor and any other associated costs to make any repairs that are not due to a USSM manufacturing defect. Damage to persons or property or other loss or injury resulting from defects in the racking system or use thereof, shall not be the responsibility of USSM. USSM will not, under any circumstances, be liable for any indirect, special, incidental or consequential damages of any nature, whether based on contract, tort or other legal theory including, without limitation, business interruption costs, removal and/or reinstallation costs, reprocurement costs, loss of profit or revenue, loss of data, promotional or manufacturing expenses, overhead charges, injury to business reputation or loss of customers, even if USSM has been advised of the possibility of such damages. In all cases, USSM's total liability will be limited to the repair or replacement of racking systems products manufactured by USSM. Any product returned to USSM for replacement shall become the property of USSM.

USSM MAKES NO IMPLIED STATUTORY WARRANTY OF MERCHANTABILITY OR FITNESS OF ITS RACKING SYSTEMS FOR A PARTICULAR USE OR PURPOSE.

THIS WARRANTY CONSTITUTES THE SOLE REMEDY AND WARRANTY MADE BY U.S. SOLAR MOUNTS EITHER EXPRESSED OR IMPLIED.

Warranty Claim Procedure

Claims under this warranty will be considered if submitted by registered or certified mail to U.S. Solar Mounts Corp. 3498 Acorn Ave. Sparta, WI 54656 within 15 days following the discovery of any defect covered by this warranty, with specific details in writing, and provided USSM or its agents are permitted a commercially reasonable opportunity to examine and analyze the workmanship claimed to be defective. An authorized representative of USSM must approve any claim in writing. THIS WARRANTY, WHICH IS LIMITED AS INDICATED ABOVE, PROVIDES SPECIFIC LEGAL RIGHTS.